

GB Assembly and wiring of SIRCO PV.
F Montage et câblage des SIRCO PV.

ES Montaje y conexión de los SIRCO PV.

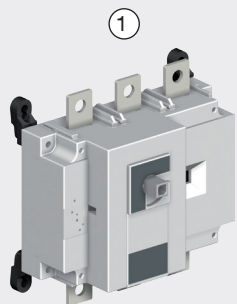

275A : 26PV3026
315A : 26PV3032
400A : 26PV3041
500A : 26PV3051

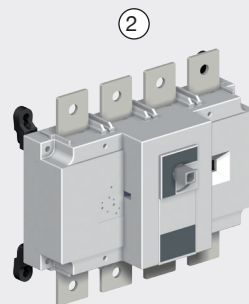

630A : 26PV4064

Switch and accessories
L'interrupteur et ses accessoires
El interruptor y sus accesorios

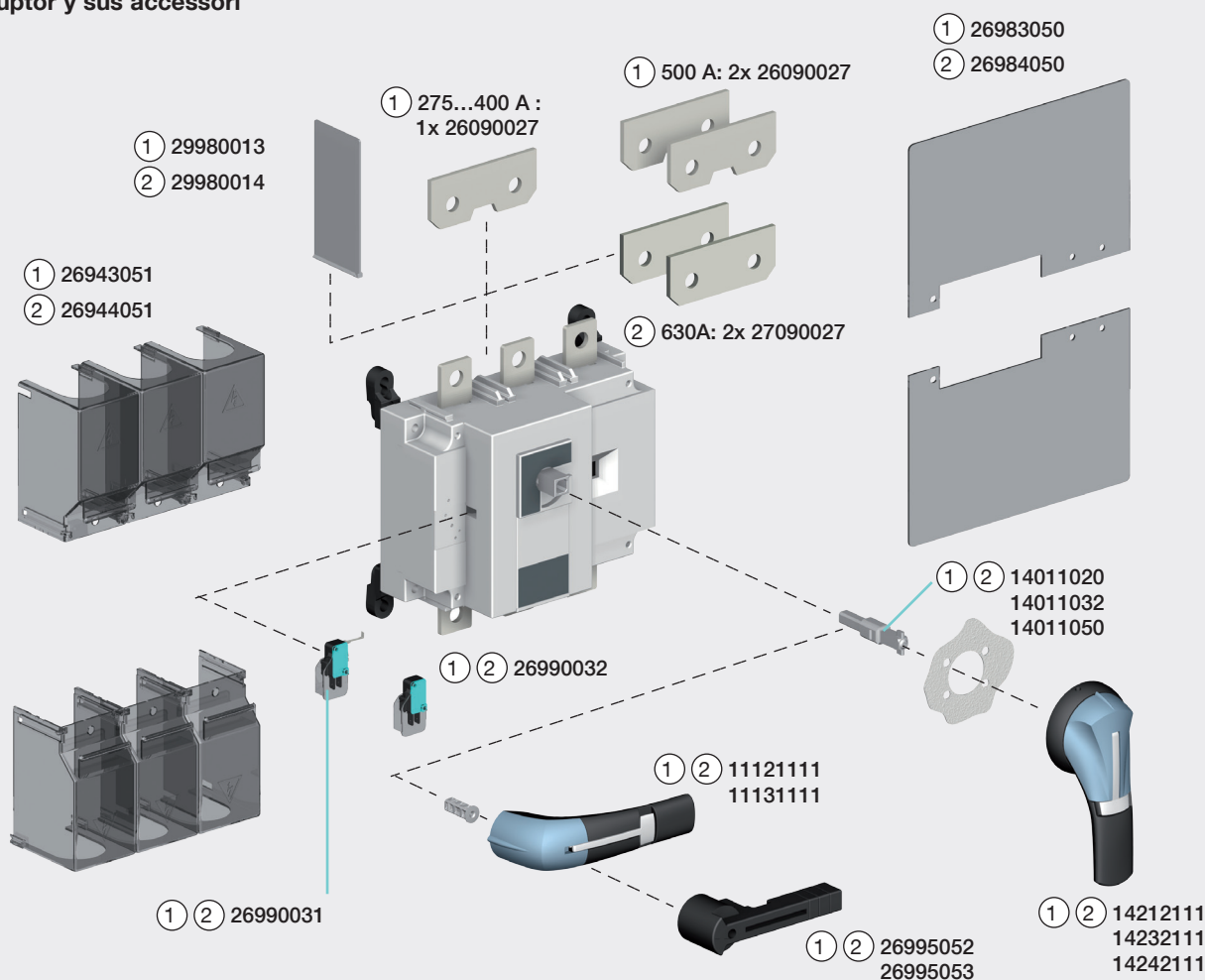

HAZARD / DANGER / PELIGRO

HAZARDOUS VOLTAGE. This equipment must be installed and serviced only by qualified electrical personnel. Turn off all power supplying this equipment before working on or inside equipment. Always use a properly rated voltage sensing device to confirm power is off. Replace all devices, doors, and covers before turning on power to this equipment. **Failure to follow these instructions will result in death or serious injury.**

TENSION DANGEREUSE. L'installation et l'entretien de cet appareil ne doivent être effectués que par du personnel qualifié. Coupez l'alimentation de cet appareil avant d'y travailler. Utilisez toujours un dispositif de détection de tension à valeur nominale approprié pour confirmer que toute alimentation est coupée. Remplacez tous les dispositifs, les portes et les couvercles avant de mettre cet appareil sous tension. **Si ces précautions ne sont pas respectées, cela entraînera la mort ou des blessures graves.**

TENSION PELIGROSA. Solamente el personal de mantenimiento eléctrico especializado deberá instalar y prestar servicios de mantenimiento a este equipo. Desenergice el equipo antes de realizar cualquier trabajo en él. Siempre utilice un dispositivo detector de tensión adecuado para confirmar la desenergización del equipo. Vuelva a colocar todos los dispositivos, las puertas y las cubiertas antes de energizar este equipo. **El incumplimiento de estas precauciones podrá causar la muerte o lesiones serias.**

PRESENCE OF MAGNET



Keep a minimum distance (>4in / 10cm) from medical equipments, inclusive pacemakers and other medical implants.

PRÉSENCE D'AIMANT



Maintenir une distance minimale (> 4in / 10cm) avec tous les équipements médicaux, incluant les pacemakers et autres implants actifs

PRESENCIA DE MAGNETISMO



Deje una distancia mínima (> 4in / 10cm) con equipos médicos, incluso marcapasos y otros implantes médicos.



547443C

Keep the instruction sheet, it is necessary for the mounting of the accessories.
 Ne jetez pas cette notice : elle sera nécessaire pour le montage des accessoires.
 No tirar ésta noticia, porque es necesaria para el montaje de los accesorios.

①

26PV3026
26PV3032
26PV3041
26PV3051

Dimensions in / mm
Dimensiones in / mm

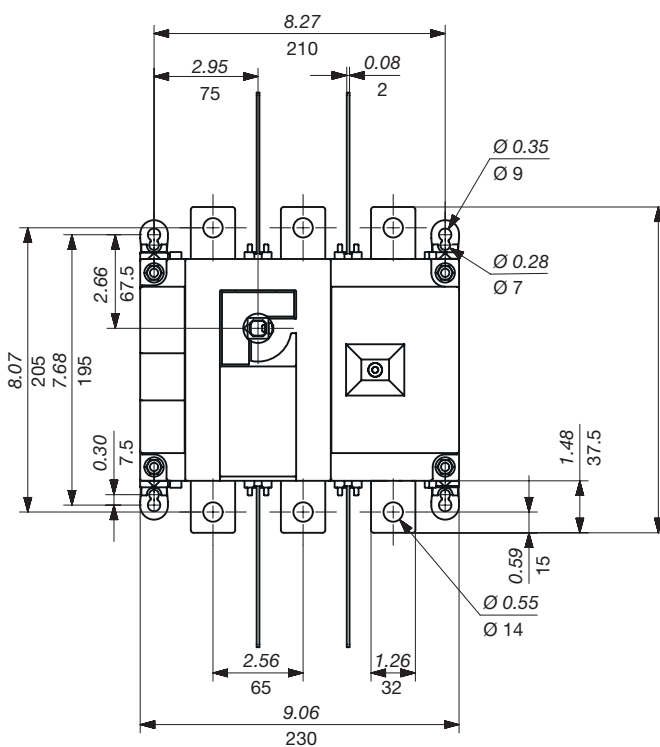
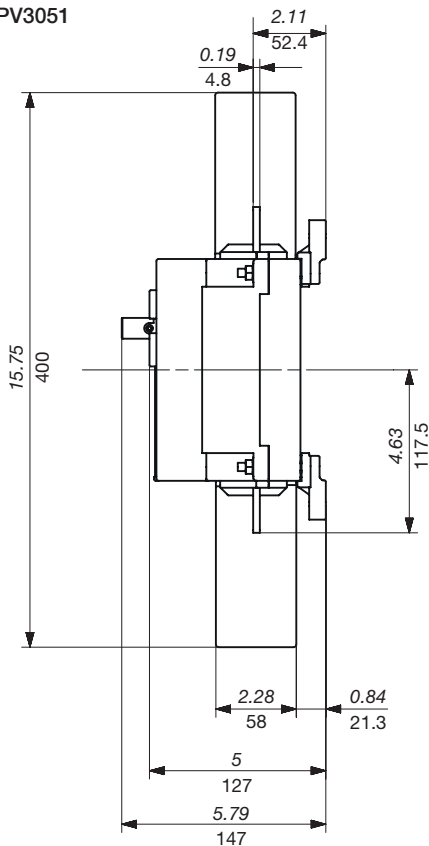

②

26PV4064

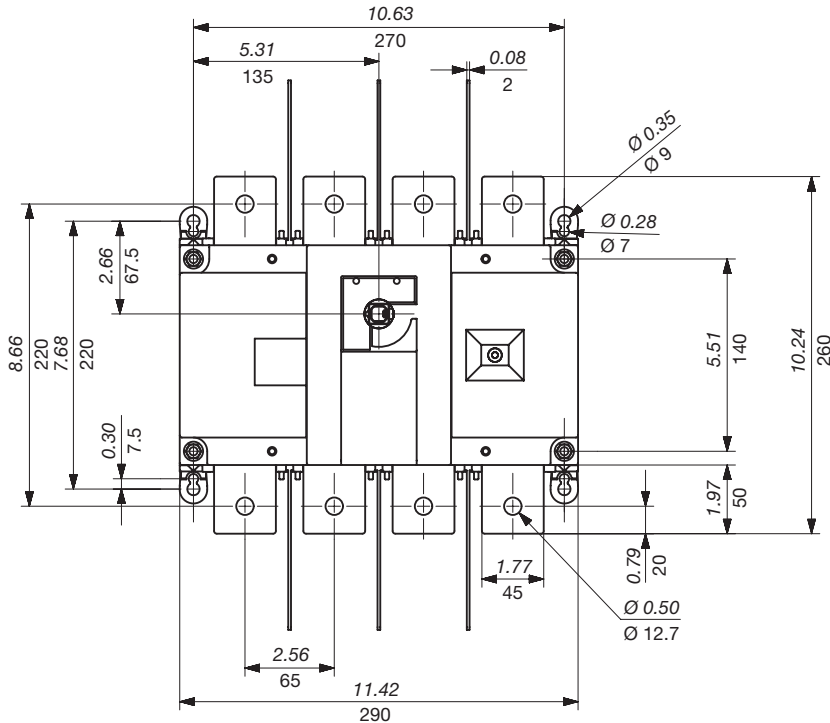
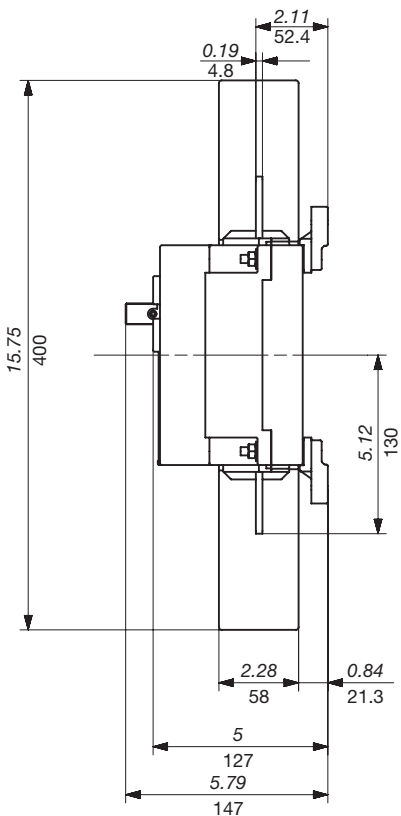

Mounting orientation / Sens de montage / Sentido de montaje

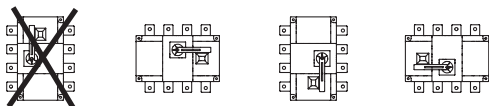

**POLE CONNECTION IN SERIES
COMPULSORY**

For comprehension reason, only one type of connection is shown. As all poles are independent and non polarized, the pole connections in series can be done between adjacent or non-adjacent poles and on the same or opposite side of the same switch layer. The minimum number of pole to be connected in series must be as shown below for the given technical characteristics. Wire bending space as well as spacings have to be according to NEC or relevant installation standard. For this, the enclosure dimension might have to be increased.

For bridging bar and serial connections not supplied by Socomec, thermal effect have to be checked.

**CONFIGURATION RACCORDEMENT
OBLIGATOIRE**

Pour une meilleure compréhension, seul un type de raccordement est décrit. Tous les pôles sont indépendants et non polarisés, le raccordement des pôles en série peut être réalisé entre pôles adjacents ou non, sur le même coté ou le coté opposé du même boîtier (avant ou arrière). Le nombre minimum de pôles à raccorder en série doit correspondre aux indications ci-dessous pour les caractéristiques techniques mentionnées. Le rayon de courbure des câbles ainsi que les distances entre conducteurs/parois doivent être selon le NEC ou la norme d'installation. Pour cela, la dimension minimum du coffret pourrait être augmentée. Pour les connexions série entre pôles/barres de pontages non fournis par Socomec, les impacts thermiques doivent être vérifiés.

**CONEXIÓN DE LOS POLOS EN SERIES
OBLIGATORIO**

Para mayor claridad, sólo se describe un tipo de conexión. Todos los polos son independientes y sin polarización así que la conexión de los polos en serie se puede realizar entre polos que están contiguos o no, en el mismo lado o en el lado opuesto del producto. Siempre de un mismo equipo. El número mínimo de polos a conectar en serie debe corresponder a las siguientes indicaciones para las características técnicas mencionadas. El radio de curvatura de los cables y las distancias entre las partes activas y pasivas respetar las normas de instalación NEC. Por ello, la dimensiones mínimas de la envolvente deberíansen aumentadas. Para la conexión serie entre los polos / pletinas de puentado no suministras por Socomec debenser verificados los efectos térmicos.

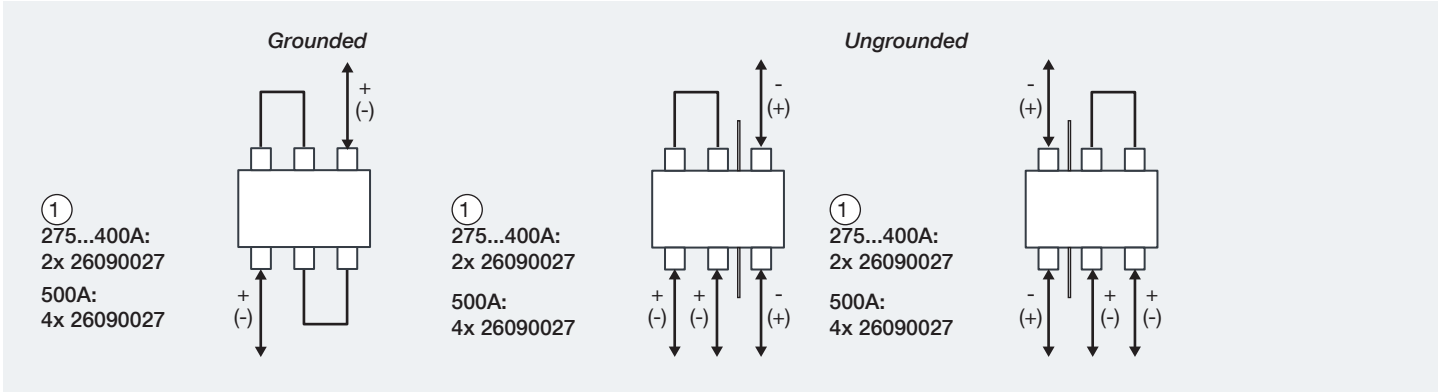
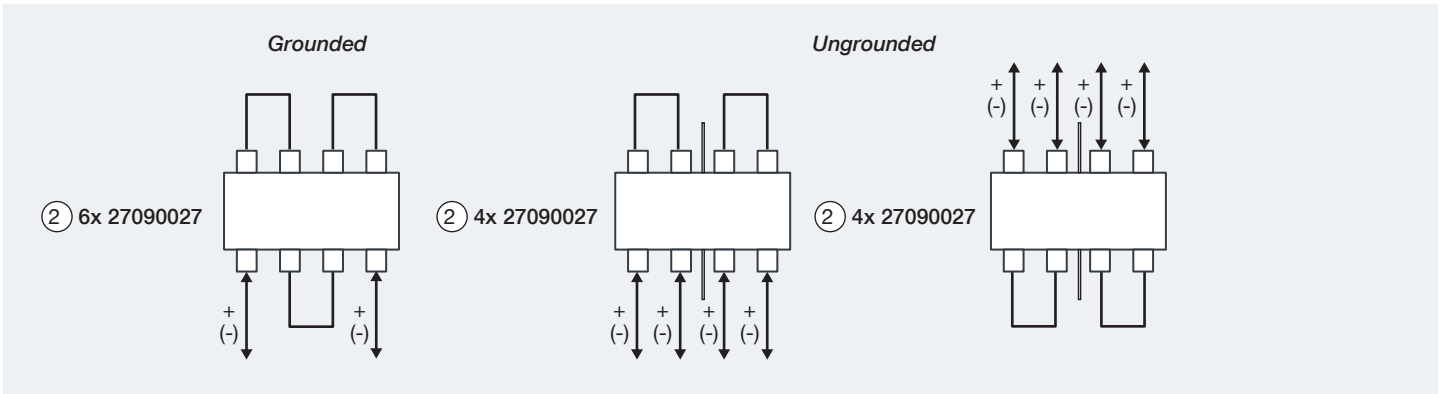
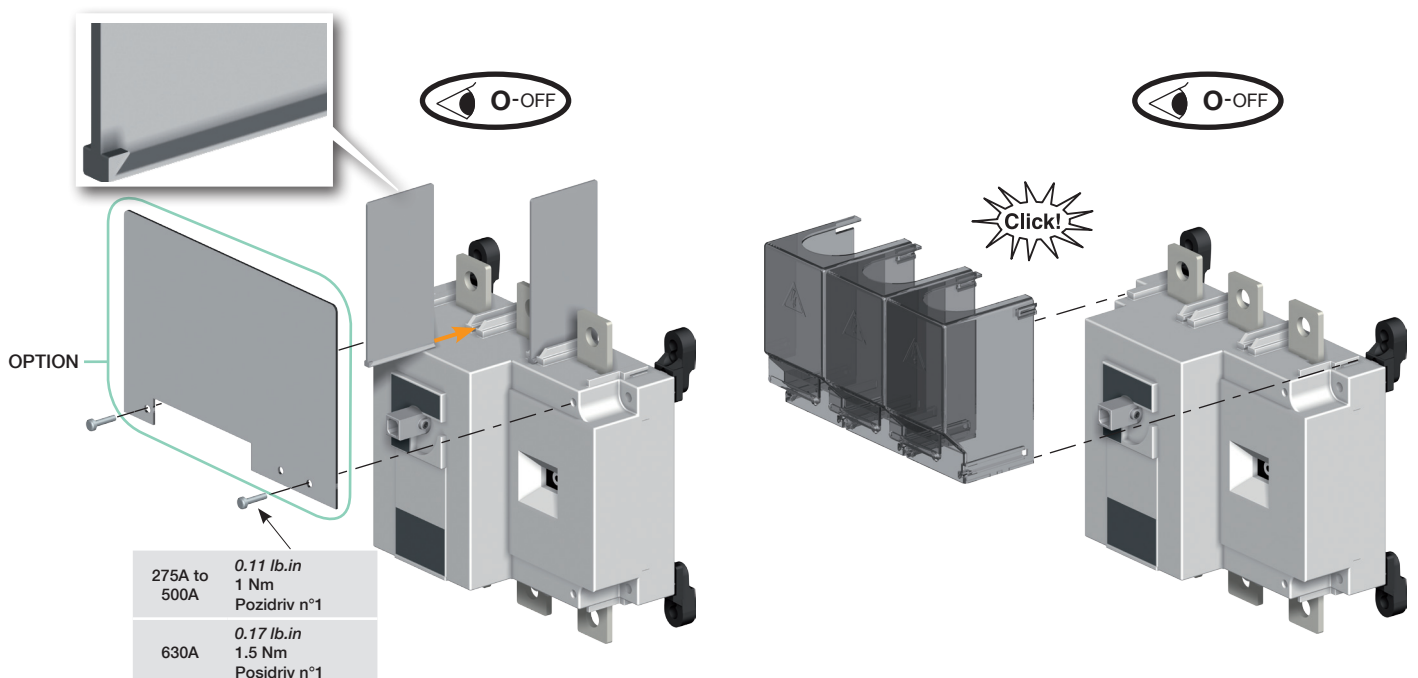
From 275 to 500 A - 1500 VDC: IEC 60947-3 [3 poles in series]**630 A - 1500 VDC: IEC 60947-3 [4 poles in series]**
Mounting of terminal screens and terminal shrouds
Montage des écrans et des cache-bornes
Montaje de los Cubrebornes

		Nominal Cu cable section Section nominale câbles rigides Cu Sección máx. de cables de cobre rígidos	Maximum Cu busbar width Largeur max. barre Cu Largo máx. (barra cobre)	Min./Max. tightening torque Couple de serrage min./max. Par de apriete mini./maxi. *	
26PV3026	275 A	185 mm ²	1.26 in / 32 mm	354.04 lb.in / 40 Nm	398.30 lb.in / 45 Nm
26PV3032	315 A	185 mm ²	1.26 in / 32 mm	354.04 lb.in / 40 Nm	398.30 lb.in / 45 Nm
26PV3041	400 A	240 mm ²	1.26 in / 32 mm	354.04 lb.in / 40 Nm	398.30 lb.in / 45 Nm
26PV3051*	500 A	2 x 150 mm ²	1.26 in / 32 mm	354.04 lb.in / 40 Nm	398.30 lb.in / 45 Nm
26PV4063*	630 A	2 x 185 mm ²	1.57 in / 40 mm	354.04 lb.in / 40 Nm	398.30 lb.in / 45 Nm

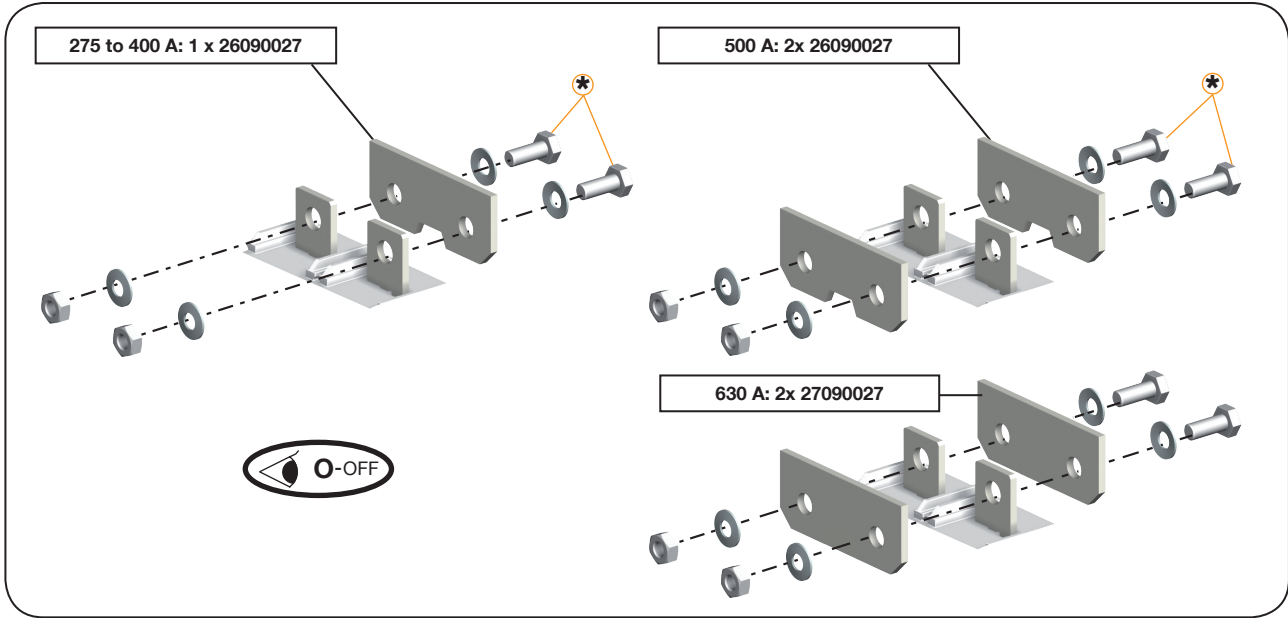

SIRCO PV devices are certified including SOCOMEC bridging bar accessories only. For other associations please ensure to contact SOCOMEC in advance to receive approval. SOCOMEC decline all responsibility when these instructions are not followed.

Les appareils SIRCO PV sont validés uniquement avec les accessoires de pontage SOCOMEC. Pour une autre association, veuillez nous contacter pour une validation préalable. Dans le cas contraire, nous déclinons toute responsabilité.

Únicamente los accesorios de puenteado SOCOMEC son validos para los commutadores SIRCO PV. Para toda otra asociacion, ponerse en contacto con nosotros para validacion. En caso contrario, declinamos toda responsabilidad.

Direct operation
Commande directe
Mando para accionamiento directo

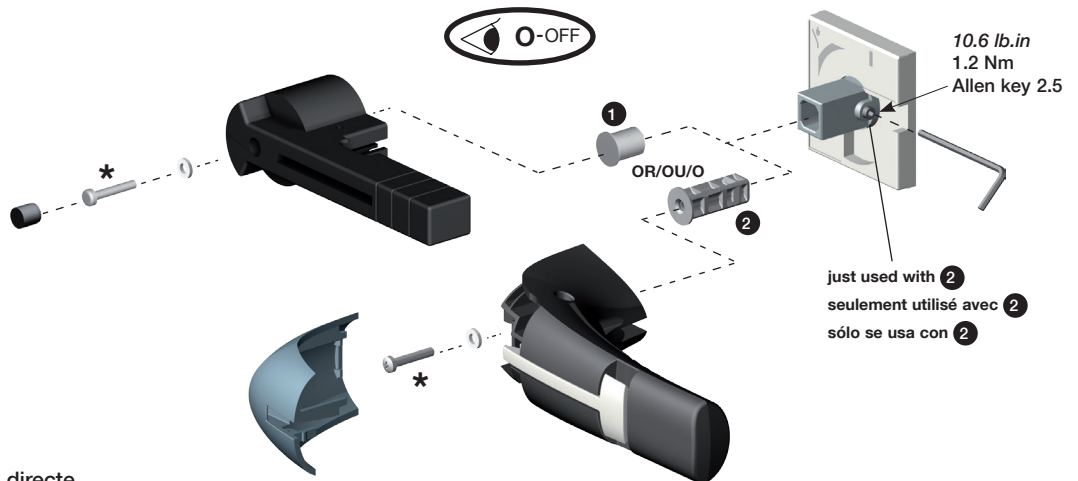
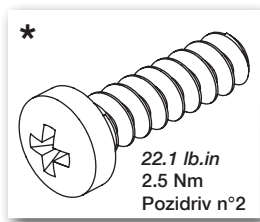

Padlocking the handle - Direct operation
Cadenassage de la poignée - Commande directe
Bloqueo del mando - mando directo

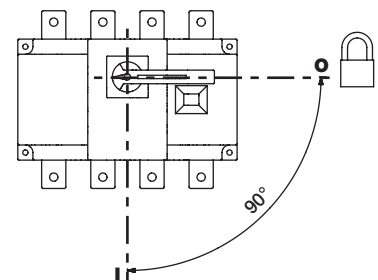
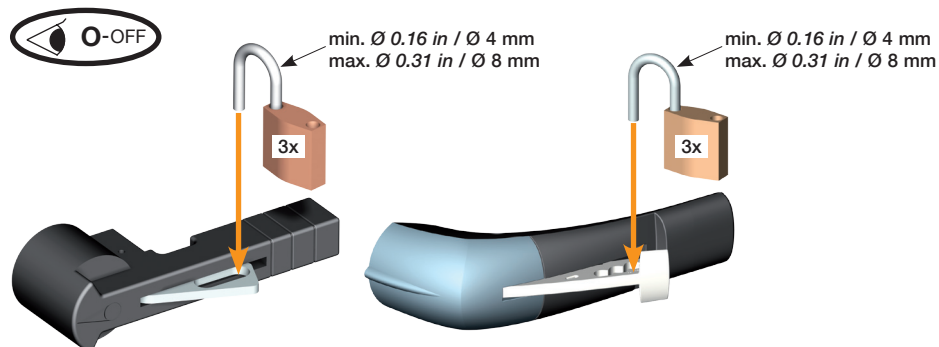

**Front operation
Commande frontale
Mando frontal**

**Door drilling / Perçage de porte
Taladro en puerta**

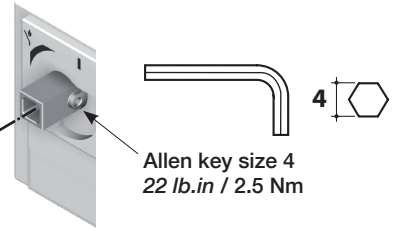
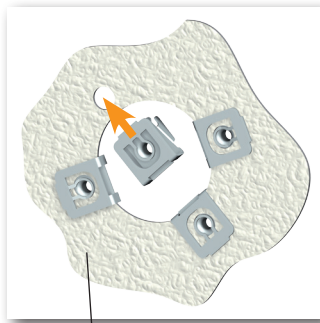
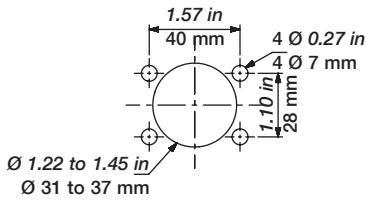

**Front operation.
Commande frontale.
Mando frontal.**

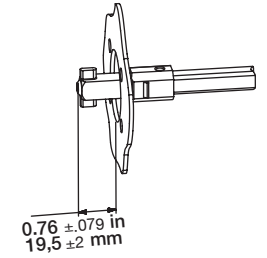

**Padlocking position
Position cadenassage
Posición de bloqueo**

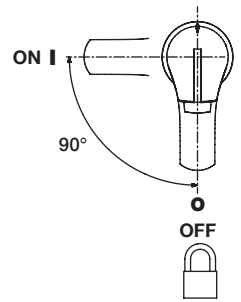

2 for IP 55 / 4 for IP 65
2 pour IP 55 / 4 pour IP 65

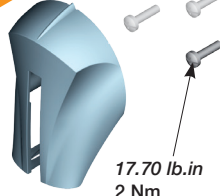

17.70 lb.in
2 Nm
Pozidriv n°2

Used for IP65
Utilisé en IP65
Utilizado para IP65

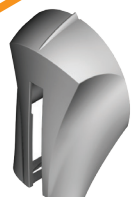

17.70 lb.in
2 Nm
Pozidriv n°2

2 for IP 55 / 4 for IP 65
2 pour IP 55 / 4 pour IP 65



**Door drilling / Perçage de porte
Taladro en puerta**

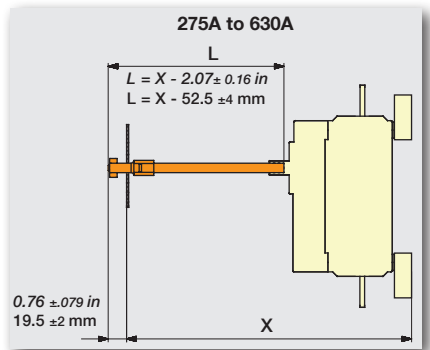
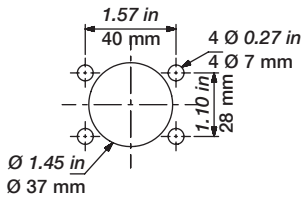

**Padlocking the handle - Front operation
Cadenassage de la poignée - Commande frontale
Bloqueo del mando - Mando frontal**

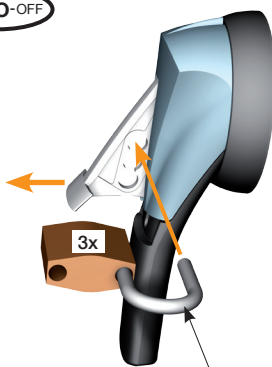
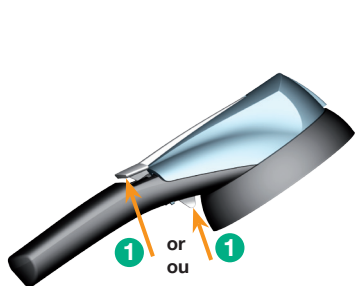

min. Ø 0.20 in / Ø 5 mm
max. Ø 0.31 in / Ø 8 mm

**IF NECESSARY
SI NECESSAIRE
SI FUERA NECESARIO**

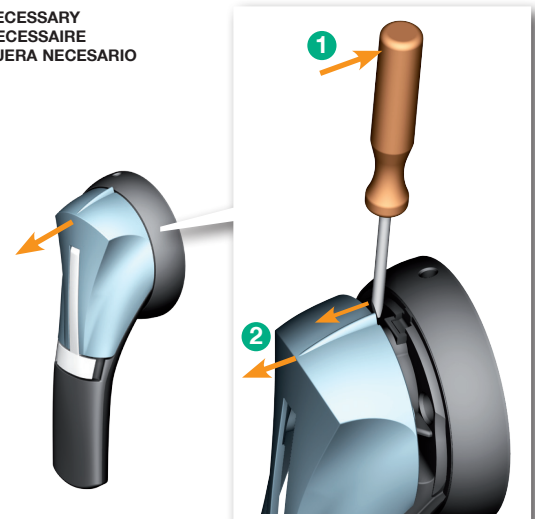

Defeating the interlock in ON position / Déverrouillage de porte en position I Desbloqueo de la puerta en posición I

⚠ DANGER / DANGER / PELIGRO		
<p>HAZARDOUS VOLTAGE</p> <ul style="list-style-type: none"> Disconnect all power before servicing. Be sure enclosure is closed securely before operating device. Testing of live equipment should only be performed by qualified service personnel in accordance with local regulations. <p>Failure to follow these instructions will result in death or serious injury.</p>	<p>TENSION DANGEREUSE</p> <ul style="list-style-type: none"> Couper l'alimentation avant intervention. S'assurer de la fermeture du coffret avant manoeuvre de l'appareil. Les essais des équipements sous tensions ne doivent être effectués que par du personnel qualifié. <p>si ces précautions ne sont pas respectées cela entraînera la mort ou des blessures graves.</p>	<p>TENSION PELIGROSA</p> <ul style="list-style-type: none"> Desenergice el equipo antes de una itervención. Asegurarse del cierre de la caja antes de manipular el equipo. Solamente el personal especializado debera probar los equipos sobre tension. <p>El incumplimiento de estas precauciones podrá causar la muerte o lesiones serias.</p>

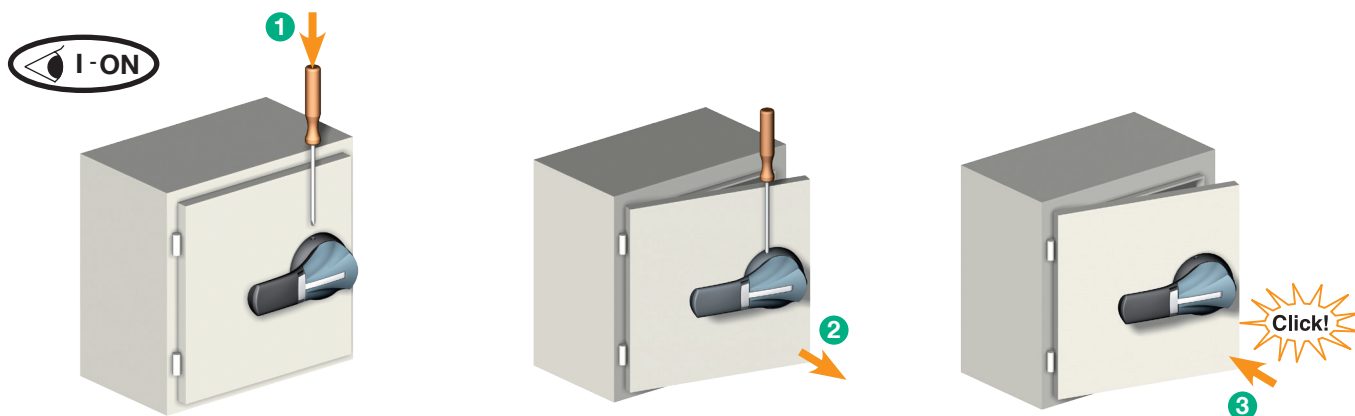

Mounting of auxiliary contacts Montage des contacts auxiliaires Montaje de los contactos auxiliares

